

## Research Article

### **Hand Written Circuit Schematic Recognition**

**Veena E<sup>1</sup>, LakshmanNaik.R<sup>2</sup>**<sup>1</sup>Department of Electronics and Communication, U B D T College of Engineering Davangere, India<sup>2</sup>Associate professor of Electronics and Communication, U B D T College of Engineering Davangere, India**\*Corresponding author**

Veena E

Email: [veena.elur@gmail.com](mailto:veena.elur@gmail.com)

---

**Abstract:** Circuit drawing is an important task especially in undergraduate courses such as electronics and digital systems. To improve human computer interaction, we have developed recognition system for the hand written circuit and its components. Here, the scanned image of a diagram is pre-processed to remove noise and converted to binary level and morphological operations are applied to obtain a clean, connected representation using thinned lines. The diagram comprises of nodes, connections and components. Using appropriate thresholds on a spatially varying object pixel density, nodes and components of the image are segmented. By the use of shape feature and Support Vector Machine (SVM) classifier components and nodes are classified.

**Keywords:** Component, Port, Contact, Circuit, Connection, Node, Support Vector Machine (SVM)..

---

#### **INTRODUCTION**

Hand-drawn sketch is a natural and direct way to express people's thought and meaning. Hand-drawn sketch is of common use in many different fields. Diagram sketches are widely used in engineering and architecture fields mainly due to the fact that a sketch is a convenient tool to catch rough idea, so that the designers can focus more on the critical issues rather than on the intricate details [1]. In the last thirty years, machine recognition of hand-written symbols in engineering diagrams has become a focus of research. The automatic acquisition of hand-sketched electronic circuit diagrams, whose solution has many useful applications that include automatic input of circuit diagrams for circuit analysis purposes, beautification of circuits for layout rendering, and human-computer interface for circuit input [2].

#### **Existing System**

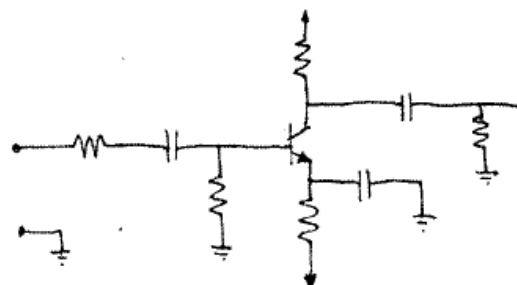
Document consist of text and graphics, to recognize whole document we need both text and graphics detection. The existing detection methods are used to detect the documents comprise of text such as languages, mathematical symbols, digits, and medical symbols etc. [3] while graphics detection has thus far generated less interest than text detection such as circuit diagrams, flowcharts, tables etc. In this work, we propose an application of digital image processing technique to detect and simulate the Hand-written circuit schematics using support vector machines classifier.

#### **System Structure**

For the purpose of implementing a quick prototype solution, a limited set of 7 components was used in the work described here. It is general enough to include all BJT circuits.

Images of hand-drawn circuit diagrams are acquired with a scanner. They are passed through the following stages –

1. preprocessing,
2. segmentation,
3. feature extraction and SVM classification,
4. detection



**Fig. 1: A hand-drawn circuit diagram**

The main objectives of this paper is the Simulation of handwritten circuit Schematics using digital image processing by using support vector machines. It involves,

- Detection of handwritten components,
- Detection of Handwritten circuit diagram
- Simulation of circuit by assigning parameters to each component

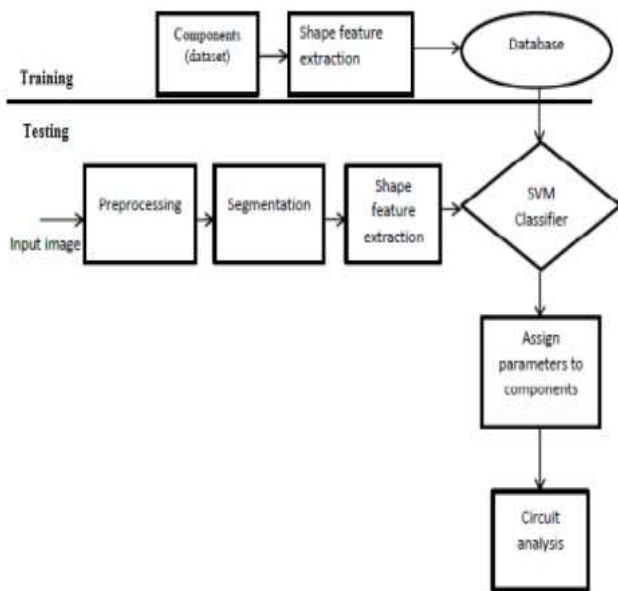


Fig. 2: Block Diagram

### Image Acquisition

In Image acquisition, the detection system acquires a scanned image as an input image. The image should have a specific format such as JPEG, BMP etc. This image is acquired through a scanner, digital camera or any other suitable digital input device.

### Pre-processing stage

The preprocessing is a series of operations performed on the scanned input image [4]. It essentially enhances the image rendering to make it suitable for segmentation. The various tasks performed on the image in preprocessing. Initially color image is converted into gray scale (monochrome conversion). Binarization process converts a gray scale image into a binary image using threshold technique. Detection of edges in the binarized image, closing and thinning of the image and area based noise removal using appropriate threshold are the operations performed in the last two stages to produce the preprocessed image. Now the processed image is suitable for segmentation stage.

### Segmentation

Segmentation is the process of breaking up the image into pieces that are small enough to be detected. It is used to separate the components and nodes, and to separate the connections, from the image. Components,

nodes and connections are all made up of lines of different lengths, orientations and curvature. For segmentation and classification knowledge of the line structures needed. Appropriate thresholds applied to the spatially varying object pixel density were used to separate components and nodes from connections and the rest of the image. Using the threshold technique ‘T’ called global threshold, image can be partitioned that is used to separate objects from the background. Depending on the gray level of scanned image is greater than or less than the threshold value ‘T’ the segmentation can be done [3].

### Shape feature extraction

Features of each component are extracted after preprocessing and segmentation on the image of circuit. This step is recognized as the heart of the system as this step has greater impact on detection rate. It helps to classify the components based on their features. Feature extraction is the name given to a group of procedures that is used for measuring the relevant shape information contained in a pattern. It makes the task of classifying the pattern easy by a formal procedure. It analyses segmented component and selects a set of features that can be used to exclusively identify the component segment. The issue of choosing the features to be extracted should be guided by the following concerns [3]:

The features should carry sufficient information about the image and should not necessitate any domain-specific knowledge for their extraction.

They should be easy to calculate in order for the approach to be feasible for a large image collection and rapid retrieval.

They should be related well with the human perceptual characteristics because users will finally decide the correctness of the retrieved images.

- Area
- Major Axis
- Minor Axis
- Roundness
- Compactness
- Centroid
- Orientation
- Eccentricity
- Convex Area
- Filled Area
- Equiv Diameter;
- Extent
- Solidity

These features are extracted from each shape for the purpose of serving as inputs to the classifier.

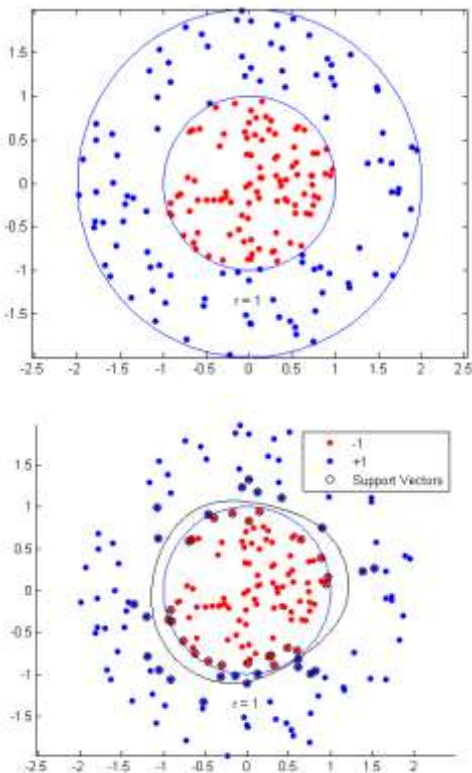
**Support Vector Machines Classifier**

The SVM (Support Vector Machine) was introduced first by Vapnik and co-workers in 1992 [5]. SVM are a group of supervised learning methods that are applied for classification or regression. The SVM classifier accepts the set of input data and after that predicts to classify them in one of the only two distinct classes. Basically, SVM classifier is trained by a given set of training data and a model is prepared to classify test data. Different types of kernel in SVM classifier are used depending on how all the samples can be classified in dissimilar classes with appropriate margin such as Linear kernel, Polynomial kernel, Gaussian Radial Basis Function (RBF) and Sigmoid (hyperbolic tangent) [3]. In this paper we are using the Gaussian Radial Basis Function (RBF).

Even though the rbf classifier can separate the classes, the result can be overtrained.

Generate 100 points uniformly distributed in the unit disk. To do so, generate a radius  $r$  as the square root of a uniform random variable, generate an angle  $t$  uniformly in  $(0, 2\pi)$ , and put the point at  $(r \cos(t), r \sin(t))$ .

Generate 100 points uniformly distributed in the annulus. The radius is again proportional to a square root, this time a square root of the uniform distribution from 1 through 4.



**Fig. 3: The points and plot circles of radii 1 and 2 for comparison**

Train an SVM classifier with Kernel Function set to 'rbf' and Box Constraint set to Inf. Plot the decision boundary and flag the support vectors.

**Detection and Simulation**

The objective of detection is to interpret the circuit taken from the scanner. In detection same series of operations are carried out, comparing the features extracted with simulation of trained classifier the circuit is detected.

Then based on SVM classifier the components are detected and redrawn. Finally the redrawn circuit is used for simulation purpose by substituting values for each component to generate output waveforms/characteristics graph

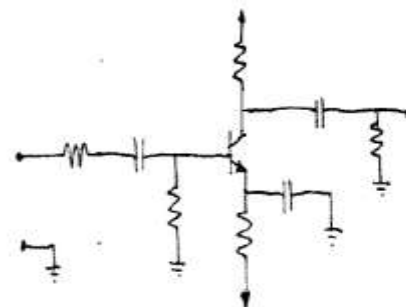
**RESULTS AND CONCLUSION**

The snapshots of the results of Simulation of Handwritten Circuits are as follows:

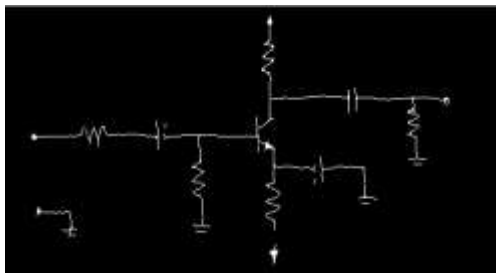


**Fig. 4: Snapshots of the results of Simulation of Handwritten Circuits**

The fig. 5 shows the snapshot of preprocessed stage of the circuit which includes the scanned input image, binarized image, segmented and node identified image, component traced image.



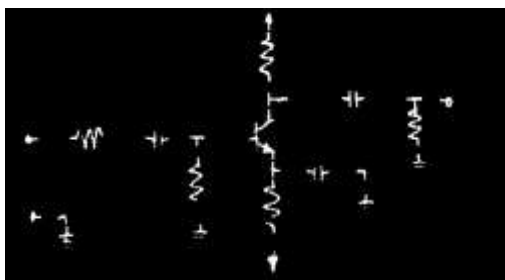
**Scanned input image**



Binary image



Node identified image



Component traced image

Fig. 5: The snapshot of preprocessed stage of the circuit

image, feature extraction, classification and detection and simulation of circuit. A Support Vector Machine classifier seems to be better than other techniques used for Simulation of Handwritten circuit schematics using digital image processing [3].

**REFERENCES**

1. Calhoun C, Stahovich TF, KurtogluT, Kara LB; Recognizing multi-stroke symbols.In Proc. AAAI Spring Symposium on Sketch Understanding, Palo Alto, USA, 2002: 15-23.
2. Sala P; A recognition system for symbols of electronic components in hand-written circuit diagrams. Available from [https://www.academia.edu/463096/A\\_recognition\\_system\\_for\\_symbols\\_of\\_electronic\\_components\\_in\\_hand-written\\_circuit\\_diagrams](https://www.academia.edu/463096/A_recognition_system_for_symbols_of_electronic_components_in_hand-written_circuit_diagrams)
3. Angadi M, LakshmanNaika R;Handwritten circuit schematic detection and simulation using computer vision approach. International Journal of Computer Science and Mobile Computing. 2014; 3(6): 754-761
4. Babu M; Identitystring generation for offline handwritten Hindi character recognition. International Journal of Research in Computer Applications and Robotics, 2014; 2(5): 132-136.
5. Vapnik V; The nature of statistical learning theory, Springer, 1995.

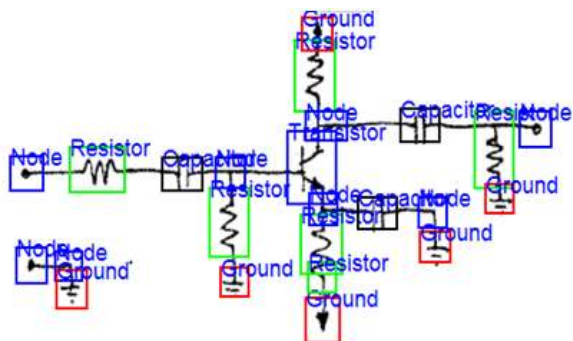


Fig. 6: Snapshots Detection of Circuit components and node

Fig. 6 shows the snapshots Detection of Circuit components and labeling circuit. Each component is detected by its equivalent circuit.

**CONCLUSION**

This work is a system Simulation of Handwritten circuit schematics using digital image processing. The Simulation starts with preprocessing the acquired